

Programmable Digital Pulse Generator for Fast High-Voltage Switches

Version 1.00



User Manual

Document version 1, created on Nov-18-2019

Contents

Safety Information	4
Technical Data.....	5
Characteristics	5
High-Voltage Output	5
Control Output.....	5
Security	5
Trigger Output.....	5
Monitoring	6
Human Interface.....	6
Power Supply	6
General	6
Shipment Contents.....	7
Description	8
General	8
Fast High-Voltage Switches.....	8
Pulse Generator	9
Embedded Safety Precautions	15
Control and Indication Elements	15
Human Interface.....	16
Terminals	17
Installation	22

Figure List

Fig. 1. Simplified circuit diagram of one switch channel.	9
Fig. 2. Block diagram of the modules at the front side of the main device.	10
Fig. 3. Block diagram of the modules at the rear side of the main device.	11
Fig. 4. The front panel of the pulse generator.	13
Fig. 5. The rear panel of the pulse generator.	14
Fig. 6. The output high-voltage connector.	17
Fig. 7. The output signal connector.	18
Fig. 6. The vacuum electronic board.	21

Table List

Tab. 1. Pin layout of the high-voltage output connector.	18
Tab. 2. Pin layout of the signal output connector.	20

Safety Information

- The device may be installed and used by authorized and instructed personnel only. Read this manual carefully before installing and using the device. Always follow the safety notes and warnings in this manual.
- The device is designed for indoor dry laboratory use only. Before powering the device on, the device temperature must accommodate to the ambient temperature to avoid moisture condensation. This is especially relevant after transportation.
- Do not operate the device if it is damaged or not functioning properly. Never use damaged cables or accessories.
- Do not open the device case, install replacement parts, or perform modifications to the device. There are no user serviceable parts inside.
- To avoid damage, connect the line cord to a properly wired and grounded receptacle only. Be sure that the mains voltage and the fuse rating match the device specification. Never operate the device during thunderstorms.
- Never use corrosive or abrasive cleaning agents or polishes, avoid the usage of organic solvents. If necessary, clean the device with a soft moist cloth. Make sure that the device is completely dry and free from contaminants before powering it on.

! **Warning:** The digital pulse controller is an electronic device that is sensitive to electrostatic electricity. While manipulating with the controller, the ESD (*Electro-Static Discharge*) protection rules must be kept in mind.

Technical Data

Characteristics

- controller for 5 independent fast high-voltage switches
- voltage source of 5 independent high voltages
- 19" case, bench top or rack mount
- digital controller with remote control via USB

High-Voltage Output

- connector:
Amphenol MIL-DTL-26482 receptacle PT00SE-16-8S(023)
(panel receptacle with 8 female contacts)
- output voltages:
4x 0..+750 V, 1x 0..-750 V (5 independent outputs)
- output current: >10 mA continuous

Control Output

- connector:
Amphenol Eco-Mate RM receptacle RT0W01832SNH-K
(panel receptacle with 32 female contacts)
- output voltages:
4x 0..+750 V, 1x 0..-750 V (5 independent outputs)
- output current: >10 mA continuous

Security

- four interlock loops (short circuit enables the power switch):
two pins at each output connector
two BNC sockets at the front and rear panels
- overcurrent protection: output current limiter of all supply voltages
- overtemperature protection:
temperature sensors at heatsinks and in ICs
(shutdown and restart temperatures freely programmable)

Trigger Output

- connector: BNC socket
- levels: TTL (low < 0.4 V, high > 2.4 V)
- output impedance: 50 Ω

- start and stop slopes:
settable with a resolution of 10 ns
slope duration: < 5 ns

Monitoring

- LEDs: Activated, Interlock, Failure
- supply voltage monitoring
- temperature monitoring
- high-voltage monitoring
- fan monitoring

Human Interface

- monochrome LCD display 128x64 pixel
pixel size: 0.5 mm
pixel color: yellow, background: blue
background illumination: white LED
- keypad: 5 keys: 4x direction + 1x "enter"
- rotary encoder: 24 positions per revolution, integrated press button
- optional external shutdown button via the interlock loop

Power Supply

- rated voltage: 115/230 V $\pm 10\%$, 50/60 Hz
- power consumption:
standby (switch deactivated): <30 VA, 25 VA typ.
maximum: 60 VA
- main fuses: T 1.25 A (slow acting, size $\varnothing 5 \times 20$ mm)
- mains connection:
IEC inlet with EMC filter and integrated fuse holder

General

- 3 U 19" bench-top case:
height: 133 mm, width: 448 mm, depth: 435 mm,
total depth with handles and connectors: 486 mm,
total width with handles: 483 mm,
total height with case feet: 140 mm,
cover strips, horizontal rails: anthracite gray,
cover, bottom, and side panels: white aluminum
front and rear panels: clear anodized

- forced cooling:
 - 92-mm fan at the rear panel, 60-mm fan in the pulse controller,
 - temperature-dependent switching, monitored fan operation,
 - warning on fan failures
- weight: 6.2 kg
- cleaning: use moist cloth only, avoid use of organic solvents

Shipment Contents

- digitally-controlled high-voltage pulse generator 19-AMX800-5FD
- vacuum board AMX800-5F with 5 switches AMX800F
- output high-voltage and control-signal cables, length 2 m
- line cord (universal IEC mains lead, length 1.8 m)
- control software
- user manuals in electronic form

Description

General

This document describes the digitally-controlled high-voltage pulse generator. A complete measurement system suited for driving a pulsed ion gun consists of the abovementioned device, a vacuum electronics board, and connection cables.

The pulse generator is a combination of high-voltage power supply units and a programmable digitally-controlled pulse generator. It is fitted into a metallic 19" case, the front and rear panels are shown in Fig. 4 and Fig. 5.

The pulse controller is described in its individual manual (see the device homepage at www.cgc-instruments.com/Miscellaneous/AMX800-5FD). Beside its intrinsic function, the pulse controller contains also control and monitoring circuits of the whole device, i.e. the pulse generator. The function of them is briefly described in this document, for further details, please consult the manual of the pulse controller.

Fast High-Voltage Switches

Fig. 1 shows a simplified circuit diagram of one switch channel. The main printed-circuit board AMX800-5F integrates five switch channels AMX800F, each of them is optimized for its particular function. The electrode attached to the output V_{out} is switched by fast high-voltage MOSFETs T1 and T2 to the positive (V_{pos}) or negative (V_{neg}) supply rail, respectively. The voltages V_{pos} or V_{neg} are provided by the digitally-controlled amplifiers, instead of one of the voltages, the ground potential is used.

The optional resistors R1 and R2 are used to slow down one of the slopes, this speeds up the opposite one. The output voltage can be monitored by a capacitively-compensated voltage divider with a ratio of 1:100 (R3, R4, C1, C2). The MOSFETs are controlled by isolated gate drivers OC1 and OC2 with LVDS inputs. These inputs LVDS-HS and LVDS-LS are controlled by pulses generated in the FPGA in the pulse controller "PULS-CTRL10". The pulses for the high-side (LVDS-HS) and the low-side (LVDS-LS) switch must be delayed with respect to each other to prevent cross conduction of both MOSFETs and to improve the dynamic response. On the MOSFET side, the gate drivers OC1 and OC2 are supplied by special switching-mode power

Block diagrams of the circuits in the main device are shown in the Fig. 2 and Fig. 3. The modules at the rear side produce all supply voltages. The supply voltages for digital circuits (+12V, +5V, and +3V3) are galvanically connected with the device ground, i.e. the protective earth (the PE wire). The supply voltages for analog circuits ($\pm 15V$ and $\pm 780V$) are galvanically isolated, their ground is provided by connecting the device to the vacuum chamber.

All power supplies for analog circuits are precise linear regulators, the

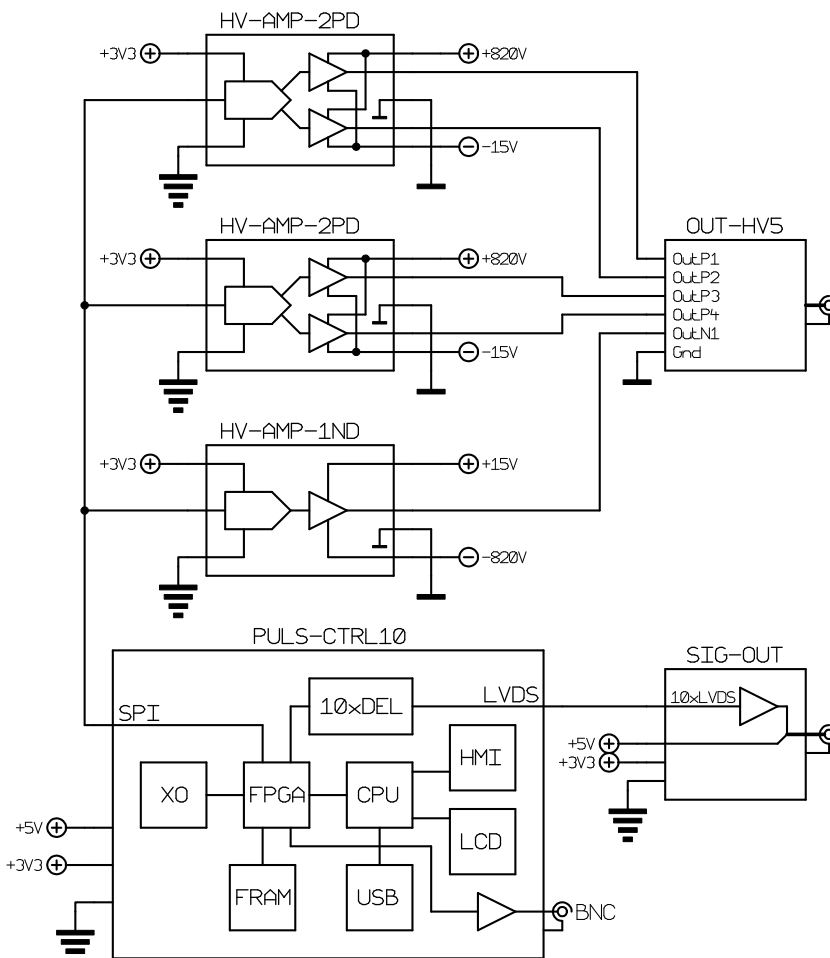

Fig. 2. Block diagram of the modules at the front side of the main device.

supply for digital circuits is a switching-mode regulator. The mains transformer (TR) is toroidal, to reduce the inrush current, an inrush-current limiter (ICL) is used.

At the front side, three amplifier modules (2x HV-AMP-2PD and 1x HV-AMP-1ND) with five high-voltage amplifiers are located. The amplifiers are controlled by digital-to-analog converters controlled via galvanically isolated SPI interface from the FPGA in the controller module "PULS-CTRL10". The high-voltage amplifiers produce voltages defining the final pulse amplitudes, they are fed to the output connector in the module "OUT-HV".

The controller module "PULS-CTRL10" contains an FPGA that integrates 10 pulse generators. The repetition rate is free programmable with a resolution of 10 ns and the corresponding clock signal is available at the BNC trigger output. The delays are derived from the time base given by a crystal oscillator (XO), its frequency is multiplied by a

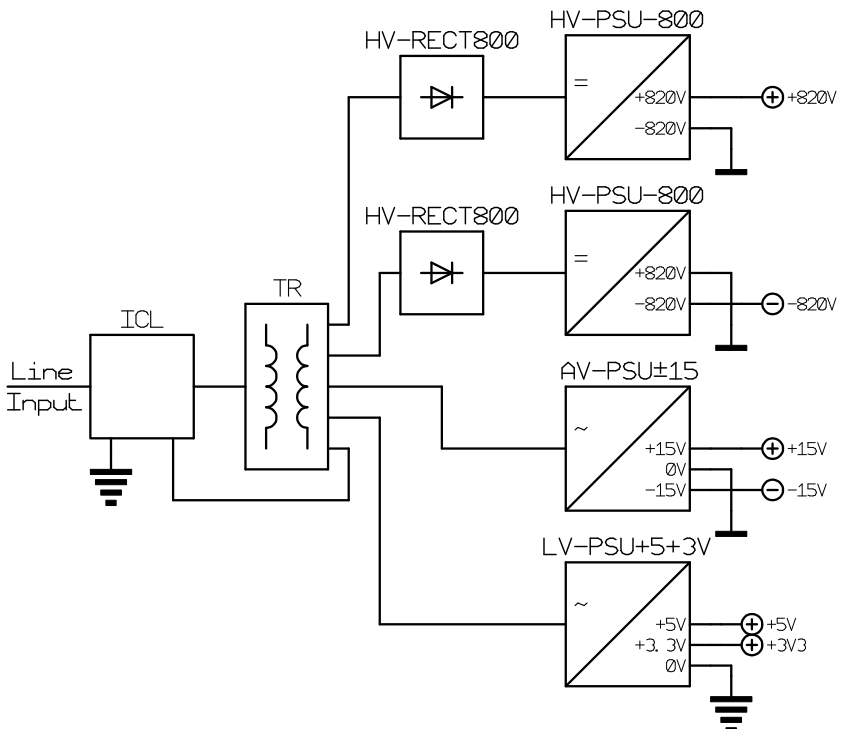

Fig. 3. Block diagram of the modules at the rear side of the main device.

PLL circuit in the FPGA. The maximum time resolution of the FPGA is 5 ns, finer time steps are reached by delay lines (10xDEL) connected to the FPGA outputs. The LVDS signals from the delay lines are buffered in the module "OUT-SIG" and fed to the output connector. The FPGA is attached to a small CPU providing the user interface. The CPU controls the graphic LCD and serves the human interface (HMI) consisting of cursor keys and a rotary encoder.

The control software running on the main CPU implements an intuitive user interface with menus and dialog boxes. The user will have the possibility to monitor the function of the device and set all working parameters. These will be stored in a non-volatile memory (FRAM) so that the device will keep all setting even after powering off. A management of up to 100 configurations is implemented. In this way, the user can switch between different parameter sets that are stored in the non-volatile memory.

The USB interface attached to the CPU and available at the front side of the controller can be used for remote controlling the device. A simple Windows™ GUI application can be used to emulate the direct manual control at the front panel.

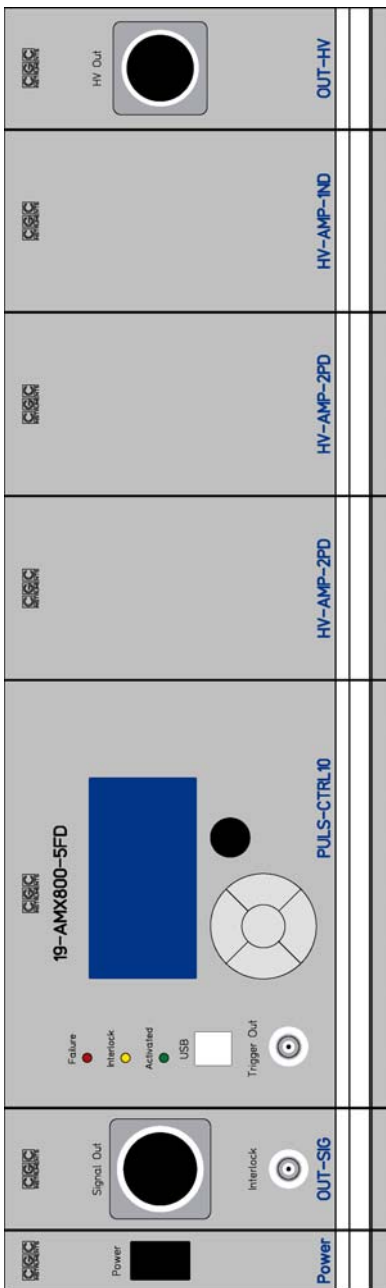

Fig. 4. The front panel of the pulse generator.

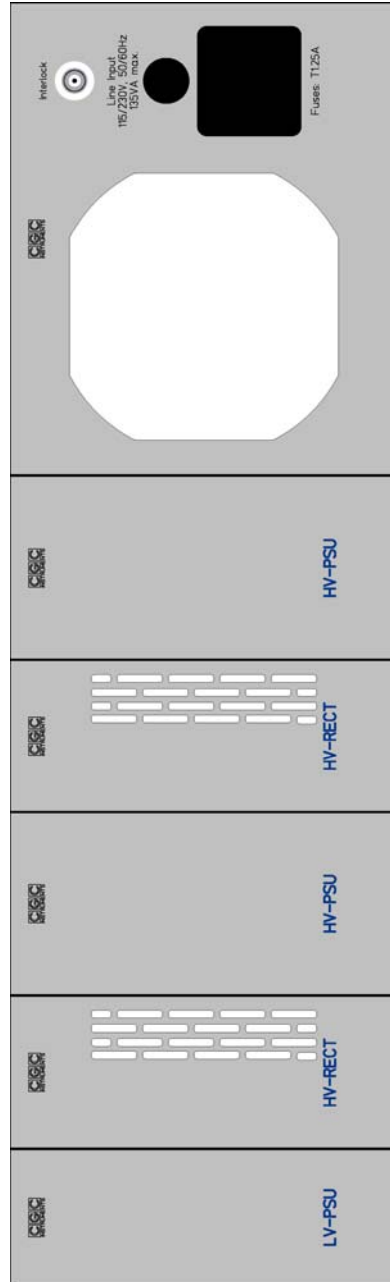

Fig. 5. The rear panel of the pulse generator.

Embedded Safety Precautions

The system is equipped with four interlock loops that disable the output if any of the loops is opened. The terminals of the interlock loops are located at the output connectors and at two BNC sockets. They are fed by the output cables to the vacuum chamber where they are either shorted or wired to the vacuum electronics board. The output is disabled if the interlock connection is opened, thus if the output cable is disconnected or broken. The sensing of any of the interlock loops can be disabled in system settings (see the manual of the pulse controller for more details) if its function is not required.

The power supplies of the device are cooled by several heatsinks located in the device housing. The heatsinks are actively cooled by a fan at the rear panel. The fan is controlled by the temperature of the power semiconductor devices. Thus, in the standby state with disabled output, the device produces only minimal acoustic noise, since the fan is typically turned off. Under operation, the heatsink temperature increases and the fan is activated. Under certain conditions, the cooling power of the device is not sufficient and the power semiconductor devices could overheat. This may happen if the output is overloaded or even shorted, if the ambient temperature is high, or if the fan fails. To prevent this from happening, the device is deactivated if the temperatures exceed a preset level (see the manual of the pulse controller for more details).

Control and Indication Elements

All control elements are located on the front panel of the pulse controller (see Fig. 4).

Using the rocker switch "Power", you can power the device on or off. When powered on, the three LEDs at the front panel of the module "PULS-CTRL10" ("Failure", "Interlock", and "Activated") light and the display turns on.

The LED "Interlock" shows the state of the interlock loops. It lights yellow, if the interlock loops are closed, i.e. if the corresponding contacts are shorted. When any of the loops is open, the LED "Interlock" is off and the device cannot be activated, unless the particular interlock loop is deactivated in system settings (see the manual of the pulse controller for more details).

The LED "Activated" lights green if the switch output is active. This indicates that pulses with preset parameters are present at the switch outputs and shows that no failure has occurred. If the device cannot be activated, check the error message on the LCD. The most probable reason is an opened interlock loop or a wrong setting of it.

The LED "Failure" lights red if any failure occurs, i.e. if the device overheats or the fan fails. You can identify the reason for the indicated failure by inspecting the dialog boxes for monitoring the device function (see the manual of the pulse controller for more details). On a fan failure, the device continues to operate, you should, however, replace the fan as soon as possible since overheating may occur. This happens if one of the semiconductors in the device reaches the critical temperature. In such case, the device is deactivated and the output is stopped. The temperature threshold can be modified, you can also check the current temperatures by opening the dialog box for temperature monitoring on the LCD (see the manual of the pulse controller for more details).

Human Interface

The device is equipped with a graphic liquid crystal display (LCD), a set of keys (keypad), and a rotary encoder. The keys are arranged in a circle symbolizing the key function: There are four direction keys ("left", "right", "up", and "down") and a middle key for confirmation or selection ("enter").

The keys are used for navigation in menus, for selecting dialog items, or for changing values. The function of the keypad in every device state is symbolized on the LCD immediately above the keypad. A text describes the function of the middle key, alternatively just the symbol "☒" is displayed showing that the middle key can be used. Similarly, arrows show which of the keys has an influence on the operation in the current state. When a menu is active, the vertical direction keys are used to change the current selection. The right direction key as well as the middle key opens a submenu, provided it is available. The left direction key closes the submenu or the main menu if there was no opened submenu. The middle key selects the menu item and launches the corresponding action.

The rotary encoder is used to change numerical values or select items. The function of the encoder is symbolized on the LCD immediately above the encoder knob in every device state. In most situations,

the encoder uses an enhanced speed control. This enables you to precisely set any desired value or rapidly make large changes, since the value steps are proportional to the rotational speed of the encoder. You can change the corresponding value in small steps when you rotate the encoder slowly or make large changes when you spin the encoder knob rapidly. To set large numbers, the encoder speed can be further increased by pressing the direction key "left". If this feature is available, the left arrow is shown above the keys. In some situations, the encoder's push button is used to confirm the selected value or to switch the encoder function. In such cases, the symbol "☐" is shown on the LCD above the encoder knob.

For more details about the operation, see the manual of the pulse controller.

Terminals

The output high-voltage terminals are located in the connector "HV Out" at the front panel of the module "OUT-HV" (see Fig. 4). The connector is an Amphenol MIL-DTL-26482 receptacle with 8 pins (for the pin layout, see Fig. 6 and Tab. 1). The high-voltage outputs are connected to five pins. The middle pin is the analog ground of the device, it is the reference potential of the high-voltages and are connected to the cable screening. Two pins of the output connector are used for the interlock loop, they must be shorted in order to enable the device output.

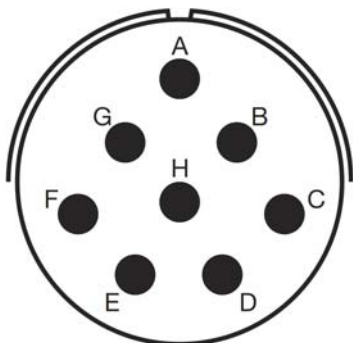

Fig. 6. The output high-voltage connector.

Tab. 1. Pin layout of the high-voltage output connector.

Pin	Signal	Description
A	VChopNeg	Supply Voltage - Chopper Negative
B	VBunch1	Supply Voltage - Buncher 1
C	VChopPos	Supply Voltage - Chopper Positive
D	ILockN	Interlock Loop - Negative Terminal
E	ILockP	Interlock Loop - Positive Terminal
F	VBunch2	Supply Voltage - Buncher 2
G	VBunch3	Supply Voltage - Buncher 3
H	AGnd	Analog Ground

The terminals of the switch control signals are located in the connector "Signal Out" at the front panel of the module "OUT-SIG" (see Fig. 4). The connector is an Amphenol Eco-Mate receptacle with 32 pins (for the pin layout, see Fig. 7 and Tab. 2). The control signals are 10 LVDS pairs controlling the low and high side part of the particular switch. Six pins in the outer circle are the digital ground of the device and are connected to the cable screening. Four middle pins are supply voltages of +5 and +12 V. Two pins of the output connector are used for the interlock loop, they are shorted by the vacuum electronic board in order to enable the device output.

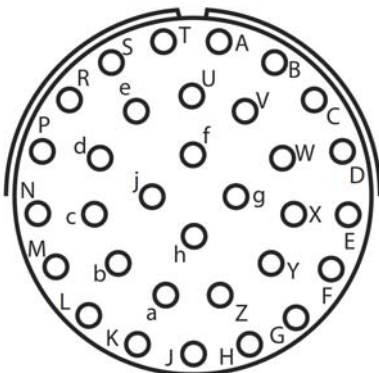

Fig. 7. The output signal connector.

Two interlock loops are available at BNC sockets located at the front panel of the module "OUT-SIG" (see Fig. 4) and at the rear panel of the device. If enabled, the contacts of the particular BNC socket must be shorted to enable the device.

At the front panel of the module "PULS-CTRL10", BNC socket for trigger output and a USB socket for remote control are located. The trigger output provides pulses with a TTL level, it has an internal impedance of $50\ \Omega$ and can be terminated by $50\ \Omega$ to improve the signal quality if a longer cable is connected to this output. The USB socket is the type B usual for peripheral devices. It can be connected to any compatible host.

For the mains connection, an IEC inlet with an EMC filter and integrated fuse holder is located on the rear panel. Use a standard line cord with the universal IEC mains lead to connect the device to the mains. To replace the fuse, remove the line cord and open the fuse holder. Insert the new fuse, close the fuse holder, and connect the line cord back to the IEC inlet.

Tab. 2. Pin layout of the signal output connector.

Pin	Signal	Description
A	OutBun3LoP	Buncher 3 Low +
B	OutBun3HiP	Buncher 3 High +
C	Gnd	Digital Ground, PE
D	OutBun2LoP	Buncher 2 Low +
E	OutBun2HiP	Buncher 2 High +
F	Gnd	Digital Ground, PE
G	OutChPosLoP	Chopper Positive Low +
H	OutChPosHiP	Chopper Positive High +
J	Gnd	Digital Ground, PE
K	OutChNegLoP	Chopper Negative Low +
L	OutChNegHiP	Chopper Negative High +
M	Gnd	Digital Ground, PE
N	OutBun1HiP	Buncher 1 High +
P	OutBun1LoP	Buncher 1 Low +
R	Gnd	Digital Ground, PE
S	ILockP	Interlock Loop - Positive Terminal
T	Gnd	Digital Ground, PE
U	OutBun3LoN	Buncher 3 Low -
V	OutBun3HiN	Buncher 3 High -
W	OutBun2LoN	Buncher 2 Low -
X	OutBun2HiN	Buncher 2 High -
Y	OutChPosLoN	Chopper Positive Low -
Z	OutChPosHiN	Chopper Positive High -
a	OutChNegLoN	Chopper Negative Low -
b	OutChNegHiN	Chopper Negative High -
c	OutBun1HiN	Buncher 1 High -
d	OutBun1LoN	Buncher 1 Low -

Pin	Signal	Description
e	ILockN	Interlock Loop - Positive Terminal
f	+5V	Supply Voltage +5 V
g	+12V	Supply Voltage +12 V
j	+5V	Supply Voltage +5 V
h	+12V	Supply Voltage +12 V

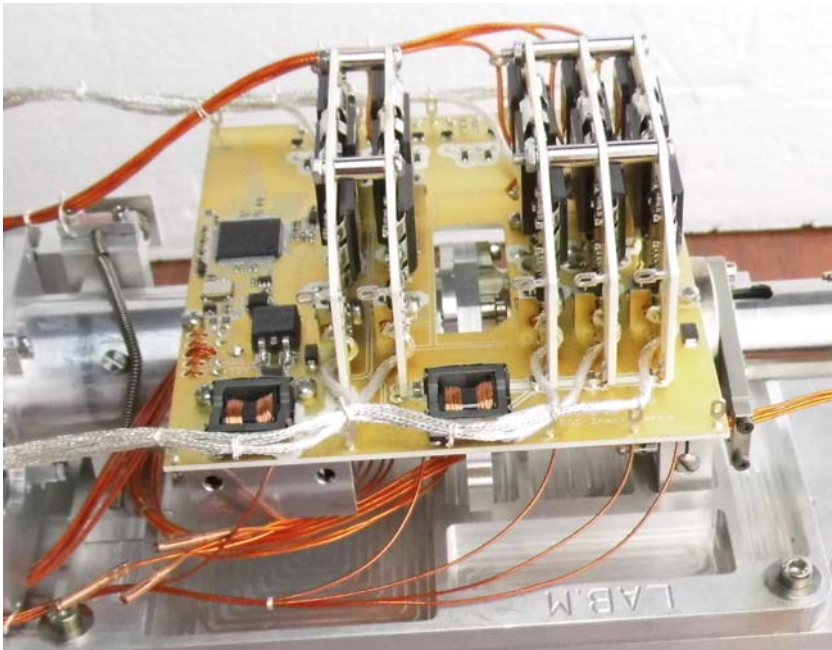

Fig. 8. The vacuum electronic board.

Installation

For shipping, the device was disassembled. You have to insert all plugin modules into the main chassis and fix them with the screws at their front panels. Check the front and rear panels shown in Fig. 4 and Fig. 5 for the order of the plugin modules.

! Be sure that the plugin modules are inserted properly at the correct position. Failing to do this will most probably damage the device when it will be powered on. Note that modules with the same name are exchangeable.

! Before powering on the system, read the user manual carefully.

To install the device, a space of at least $49 \times 49 \times 14 \text{ cm}^3$: (width \times depth \times height) on top of a stable table is required. The device weighs about 6 kg, the supporting surface must guarantee mechanical stability under this load. The installation area must be kept dry and the temperature within the range specified in the section "Technical Data". Avoid exposing the device to direct sun light since this may substantially increase the device temperature.

During operation, only the front panel of the device has to be accessible. Before installing the device in its final position, you should attach the line cord; it is connected to the IEC inlet on the rear panel (see Fig. 5). To power the device, a power mains socket with proper grounding is required. Check the voltage selector at the rear panel before powering on the device.

! **Warning:** A wrong setting of the voltage selector may permanently damage the device.

The air inlet at the rear panel must not be covered or obstructed during device operation, it must be provided with sufficiently cool air for active cooling of the device. Take necessary precautions to ensure a sufficient supply of cool air when installing the device in closed racks. Inspect and clean the fans regularly. Furthermore, use a vacuum cleaner to remove dust from the fans and from the heatsinks in the device housing. Large dust layers substantially lower the cooling power of the heatsinks (the device may overheat if the heatsinks are extremely dirty). Also the lifetime of a dirty fan can be significantly shortened.

If already connected, disconnect the vacuum board (see Fig. 8) and power on the device by toggling the rocker switch "Power". The dis-

play at the front panel of the module "PULS-CTRL10" will turn on (see Fig. 4). During the startup, the three LEDs beside the LCD ("Failure", "Interlock", and "Activated") will light for 1-2 seconds. When the device startup completes, the LED "Interlock" indicates the state of the interlock loop. The other two LEDs ("Activated" and "Failure") should be inactive. If the device behaves properly, connect the vacuum electronic board (see Fig. 8) with the enclosed cables and proceed with installing the pulse controller as described in the corresponding manual.

! **Warning:** Note that the cable for the monitoring signals must be permanently connected when the device is powered on. When the cable is disconnected, high voltages may be induced at the monitor signals that may damage the vacuum electronic board.

Please consult the manual in case of any discrepancy with this description. Should that not resolve the problem, contact the distributor or the manufacturer.